

ITE2024

Application form for rental equipment

No.	Name	Size/Specifications	Number of Order	Unit price (tax included)	Amount
1	Reception Counter	900×450×H750		8,800	
2	Reception Counter	650×450×H900		12,650	
3	H750 Exhibition Stand	1800×500×H750		25,300	
4	H1000 Exhibition Stand	1800×500×H1000		25,300	
5	H750 Exhibition Stand	1800×700×H750		30,250	
6	H1000 Exhibition Stand	1800×700×H1000		30,250	
7	H750 Exhibition Stand	1000×500×H750		12,100	
8	H1000 Exhibition Stand	1000×500×H1000		12,100	
9	H750 Exhibition Stand	1000×700×H750		14,520	
10	H1000 Exhibition Stand	1000×700×H1000		14,520	
11	H740 Exhibition Stand	W1800×D900×H740 with Tablecloth(Top:White,Side:Light Blue Color)		33,000	
12	Chain&Hang Metal fittings			380	
13	Tiered Stand	900×600×H150*3steps		15,180	
14	Tiered Stand	1800×600×H150*3steps		21,450	
15	Tiered Stand	1800×600×H300+300		15,180	
16	Tiered Stand	1800×450×H450		12,100	
17	Tiered Stand	1800×450×H300		11,330	
18	Tiered Stand	1800×300×H300		10,120	
19	Dice	450×450×H450		5,720	
20	Dice	300×300×H300		4,400	
21	Catalogue Stand(desktop)	A4 3Boxes		4,400	
22	Received Business Card Holder	Made of Acrylic		1,925	
23 ※	Punch Carpet	3m×3m		25,300	
	*Ask us if you would like other colors of Punch Carpet.				
24 ※	Pipe Chair			825	

*23 and 24 are for demo (Package Booth, Space Only) booth exhibitors.

*Prices are lease fees during the exhibition period.

· If you cancel after delivery on site, you will be charged the regular amount.

· If you have not received the equipment you applied for, please contact us or the secretariat.

Please note that we will not be able to accept claims that the package was not received after the exhibition.

Application Deadline: 1_Nov 2024(Fri)

Booth No. _____

Company Name _____

Address: _____

Person in Charge : _____

TEL : _____

e-mail : _____

*If the exhibitor and billing address are different, please write the billing address in the margin.

*The lease fee will be invoiced by Advance Planning Co., Ltd. after the exhibition period.

Where to Apply Advance Planning Co.,Ltd

TIE Hamacho Bldg 6F, 2-61-9 Nihonbashihamacho.Chuo,Tokyo,Japan 103-0007

TEL : 03-3669-2795 FAX : 03-3669-2668 e-mail : gazou@adv-ex.jp

Person in Charge : Sumiyama & Kato

Price includes tax

No.1	Reception Counter	¥8800
------	-------------------	-------

No.2	Reception Counter	¥12,650
------	-------------------	---------

No.3	H750 Exhibition Stand	¥25,300
No.4	H1000 Exhibition Stand	¥25,300

No.5	H750 Exhibition Stand	¥30,250
No.6	H1000 Exhibition Stand	¥30,250

No.7	H750 Exhibition Stand	¥12,100
No.8	H1000 Exhibition Stand	¥12,100

No.9	H750 Exhibition Stand	¥14,520
No.10	H1000 Exhibition Stand	¥14,520

No.11	H740 Exhibition Stand	¥33,000
-------	-----------------------	---------

No.12	Chain&Hang Metal fittings	¥380
-------	---------------------------	------

Price includes tax

No.13 Tiered Stand ¥ 15,180

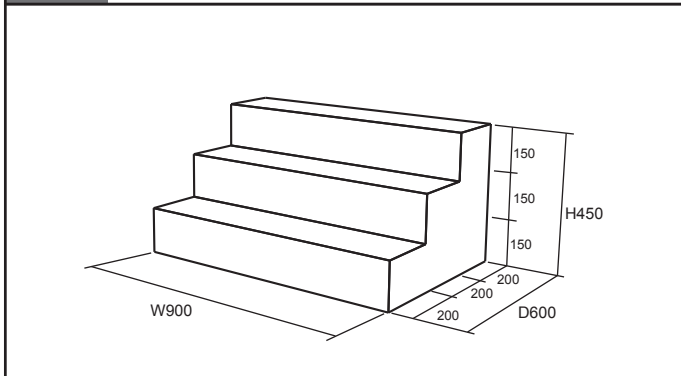

No.14 Tiered Stand ¥ 21,450

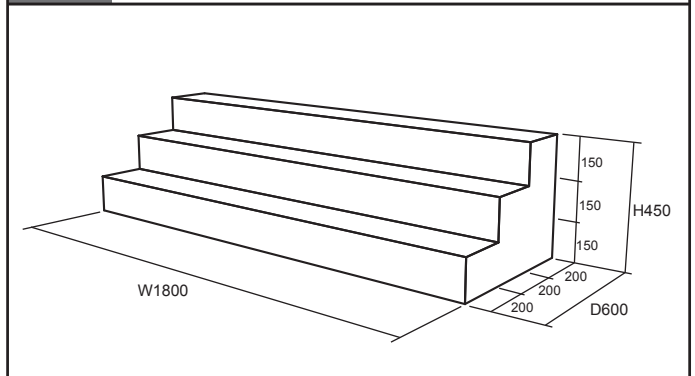

No.15 Tiered Stand ¥ 15,180

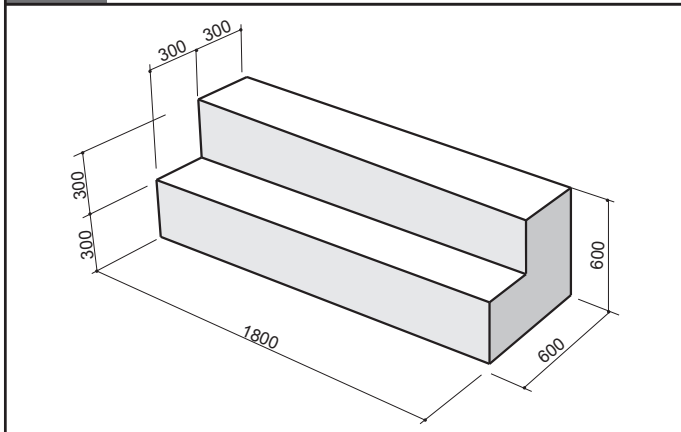

No.16 Tiered Stand ¥ 12,100

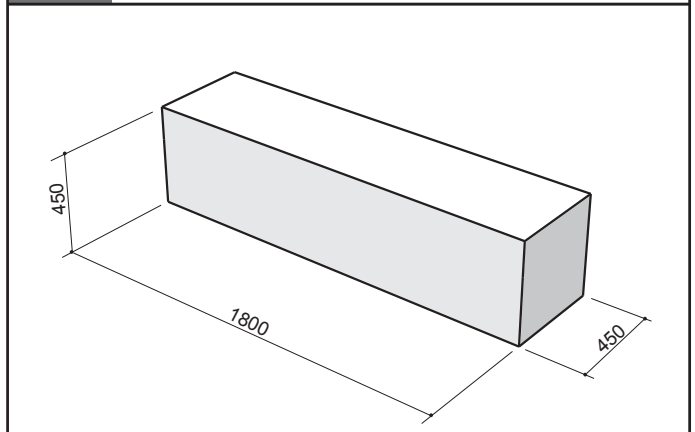

No.17 Tiered Stand ¥ 11,330

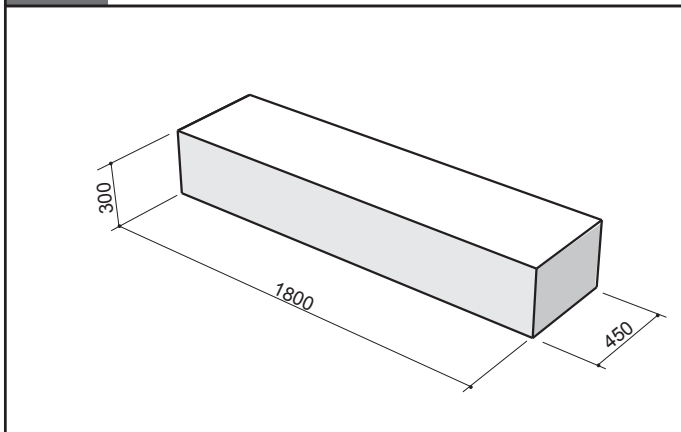

No.18 Tiered Stand ¥ 10,120

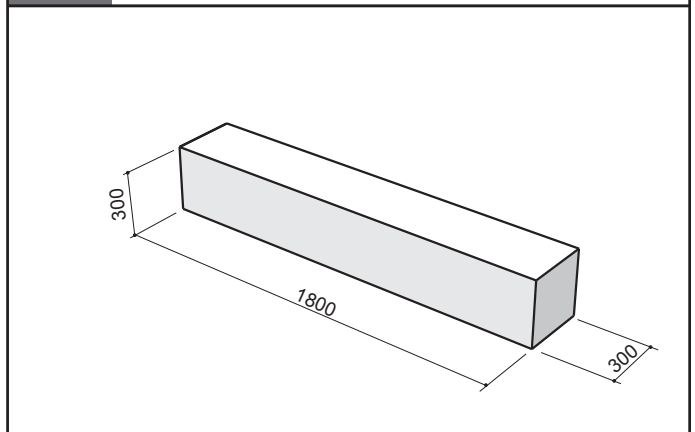

No.19 Dice ¥ 5,720

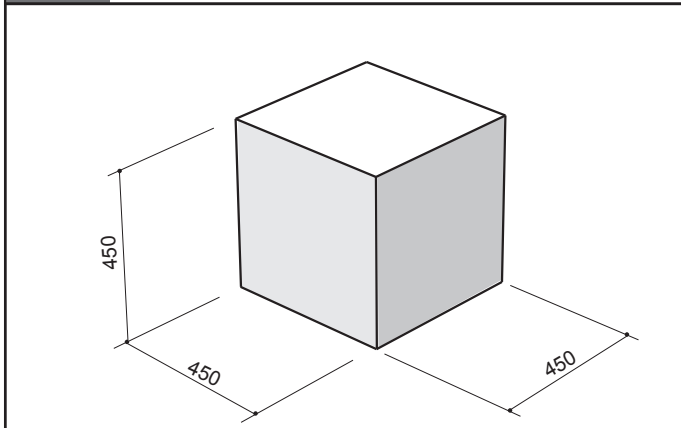

No.20 Dice ¥ 4,400

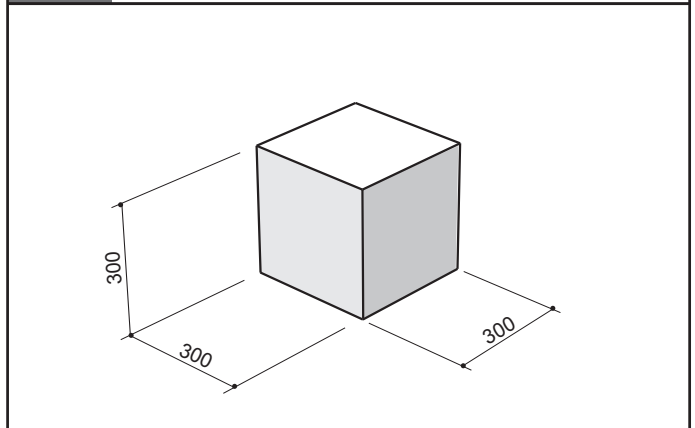

Price includes tax

No.21 Catalogue Stand(desktop) ¥ 4,400

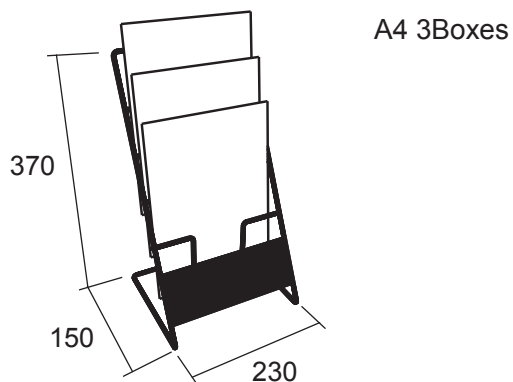

No.22 Received Business Card Holder ¥ 1,925

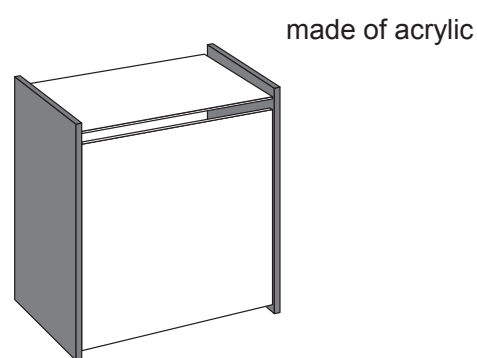

No.23 Punch Carpet ¥ 25,300

You can choose one color from the following.

Red, Blue, Yellow, Green, Brown, Purple, Orange, Pink and Gray

