

Product Name	size	Unit price (tax included)	number	color	Amount
① Change the wall color (single color) (Above the table only)	Front wall 1 booth (W1800×H1510)	¥12,650			
	1 piece for side panel (W900×H1510)	¥6,270			
② Change the wall color (single color) (From the top to the floor)	Front wall 1 booth (W1800×H2250)	¥18,920			
	1 piece for side panel (W900×H2250)	¥9,460			
③ Wall visual printing (Above the table only)	Front wall 1 booth (W1800×H1510)	¥45,650			
	1 piece for side panel (W900×H1510)	¥22,770			
④ Wall visual printing (From the top to the floor)	Front wall 1 booth (W1800×H2250)	¥58,300			
	1 piece for side panel (W900×H2250)	¥29,150			

Please specify the desired color at the URL below or by searching "Nip Roll Color".

The actual color may differ from what you see on your monitor,

so if you would like to check a sample paper, please contact Advance Co.,Ltd

<https://www.nip-co.co.jp/catalog/spacecolor/rollcolor/index.html>(From Nip Corporation Space Color Roll Color)

For visual printing, complete data submission is required.

If design is required, please contact us for a separate quote.

We will contact you by email after your application regarding the submission method.

If you wish to use the exhibition stand, please apply through ①③.

If you will not be using the exhibition stand, please apply through ②④

If you are an exhibitor with a package booth and would like wall decorations, we will provide an individual quote. Please contact the person in charge below.

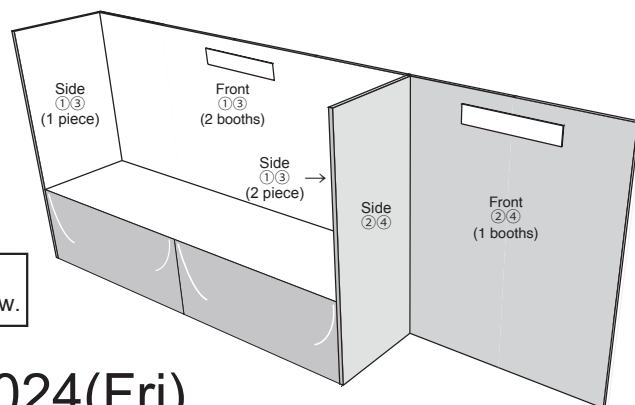

## Application Deadline: 1\_Nov 2024(Fri)

Booth No. \_\_\_\_\_

Company Name \_\_\_\_\_

Address: \_\_\_\_\_

Person in Charge : \_\_\_\_\_

TEL : \_\_\_\_\_

e-mail : \_\_\_\_\_

\*If the exhibitor and billing address are different, please write the billing address in the margin.

\*Wall decoration fees will be invoiced by Advance Planning Co., Ltd. after the exhibition period.

Where to Apply Advance Planning Co.,Ltd

TIE Hamacho Bldg 6F, 2-61-9 Nihonbashihamacho.Chuo,Tokyo,Japan 103-0007

TEL : 03-3669-2795 FAX : 03-3669-2668 e-mail : gazou@adv-ex.jp

Person in Charge : Sumiyama & Kato